

## BACKGROUND TS-2023-HIBU

In the TubeSociety Project 2023, we explored a new tube amplifier concept where the driver stage is built using op-amps and FETs, while twin power triodes drive the toroidal output transformer.

The driver section resembles the input circuit of the Trans-PP80 amplifier ([see the audioXpress May 2023 download](#)). However, the FET current flow is now utilized as a driver (with a 150 Vac amplitude) for the low-anode-impedance 6AS7-GT twin triode. The driver section is extremely linear, just like the low-impedance "voltage-source" drive of the OPT, which results in negligible magnetic distortion. All segments of the amplifier are optimally clean thanks to their local feedback loops. Therefore, no additional global feedback is needed.

To ensure that the power supply does not affect audio quality, Joost Breed designed new Maida power supply circuits, which were then implemented on PCBs.

The result? Just like in previous TS projects, we observe the remarkable soundstage where any sense of stress is absent.

The TS-2023-HIBU mains transformer includes all windings necessary to power the driver and tube output stage of a stereo amplifier. See the brief specifications below.



### Specifications TS-2023-HIBU-MAINS

Power: 140 VA  
Primary: 2 x 115 Vac  
Sec.-1: 225 V-ac / 370 mA-ac [6AS7-GT section]  
Sec.-2: 120 V-ac / 100 mA-ac [6AS7-GT section]  
Sec.-3: 6,3 V-ac / 5,5 A-ac [6AS7-GT section]  
Sec.-4: 2 x 18 V-ac / 200 mA-ac [driver section]  
Diameter: 120 mm  
Height: 45 mm  
Weight: 1,8 kg

[Valve Power Transformers. : TS-2023-HIBU-MAINS](#)

### De push-pull output transformer



### Specifications TRAFCO-VDV-8010-PPE

Application PP : 2 x EL84 / 6V6 / 6L6 / 1 x 6AS7  
Power : 10 Watt @ 40 Hz ; 20 Watt @ 57 Hz  
Impedance-prim. : 8 k $\Omega$   
Impedance-sec. : 0/4/8  $\Omega$   
UL-taps : 40 %  
Frequency range : 2 Hz to 87 kHz (-3dB 2 x EL84-UL)  
Dimensions : round 93 mm dia, height 42 mm  
Weight : 1,1 kg







## Wiring diagram HiBu 2023

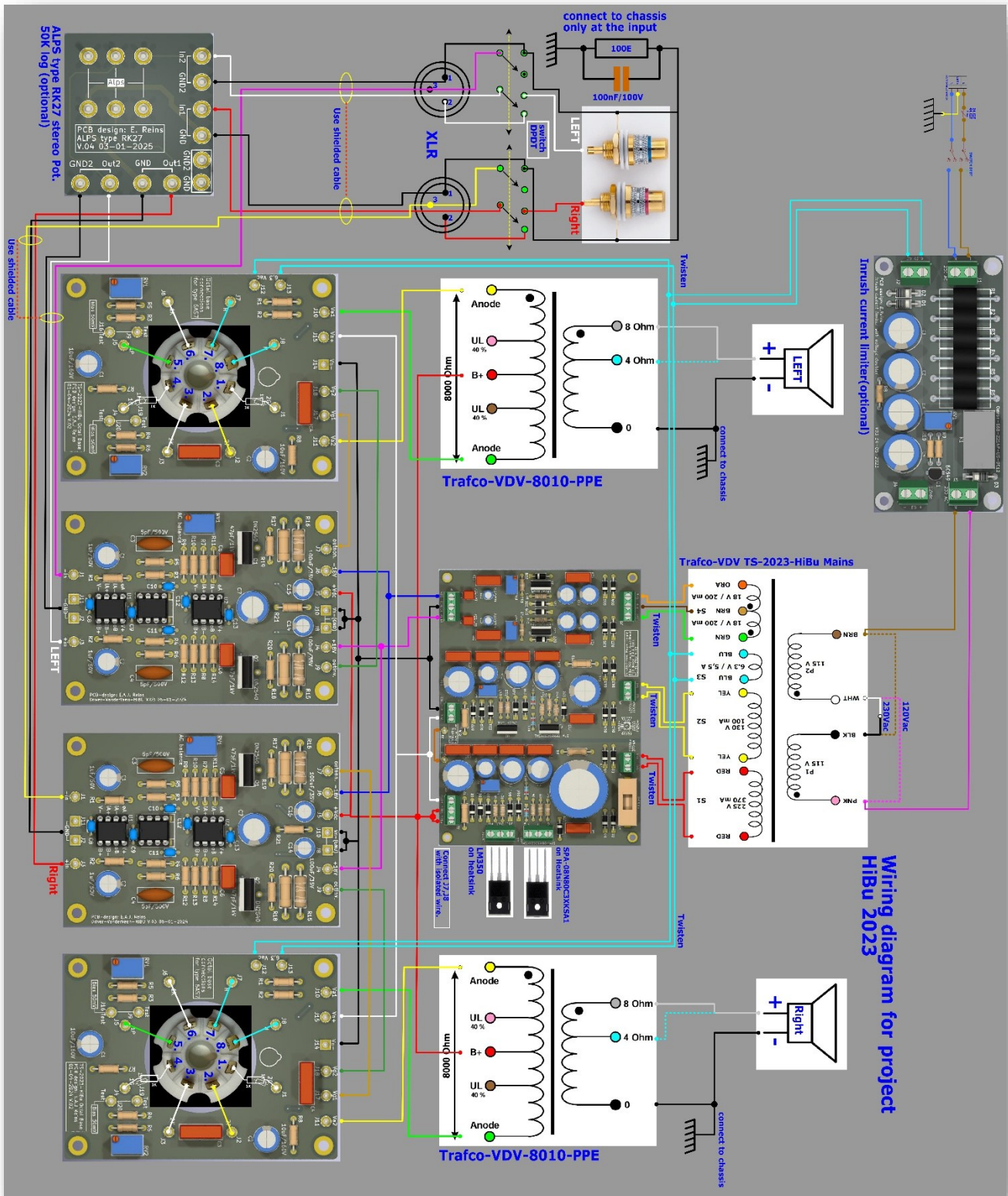

### General Tips for Soldering and Assembly

- Begin soldering with the smallest components first. Work from small to large.
- Ensure that electrolytic capacitors, diodes, and MOSFETs are oriented correctly. They have specific polarity or direction requirements.
- Twist all AC-carrying wires to prevent hum.

## Power supply HiBu PCB

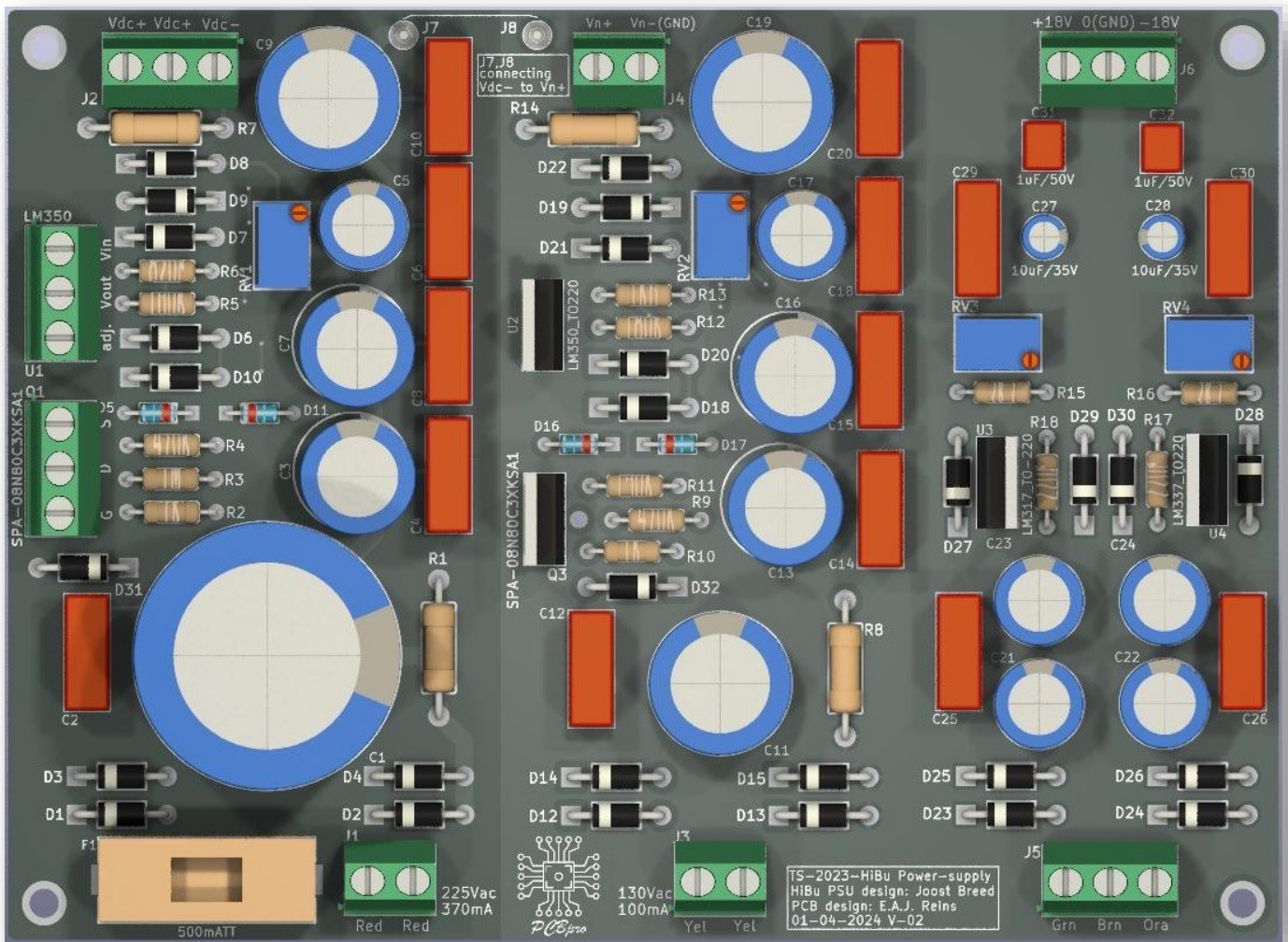

- Connect J7 and J8 using an insulated wire bridge.
- Connect the power supply board to the power transformer according to the color codes.
- Attach the voltage regulator LM350 and the MOSFET Spa-08N80CX3KSA1 to terminal blocks U1 and Q1. **Note the connections. Check the datasheet of these components for proper attachment.** Secure a heatsink to both components (included in the BOM).
- Then, power on the supply. If available, use a variac or a light bulb in series to limit the current.
- Adjust the voltages using RV1-4 and check them with a multimeter without any load.

**Vdc+ -> Vdc- = 253V (J2)**

**Vn+ -> Vn- = 150V (J4)**

**Vdc+ -> Vn- = 403V (J2->J4)**

**+18V 0 -18V (J6)**

- Turn off the power supply.



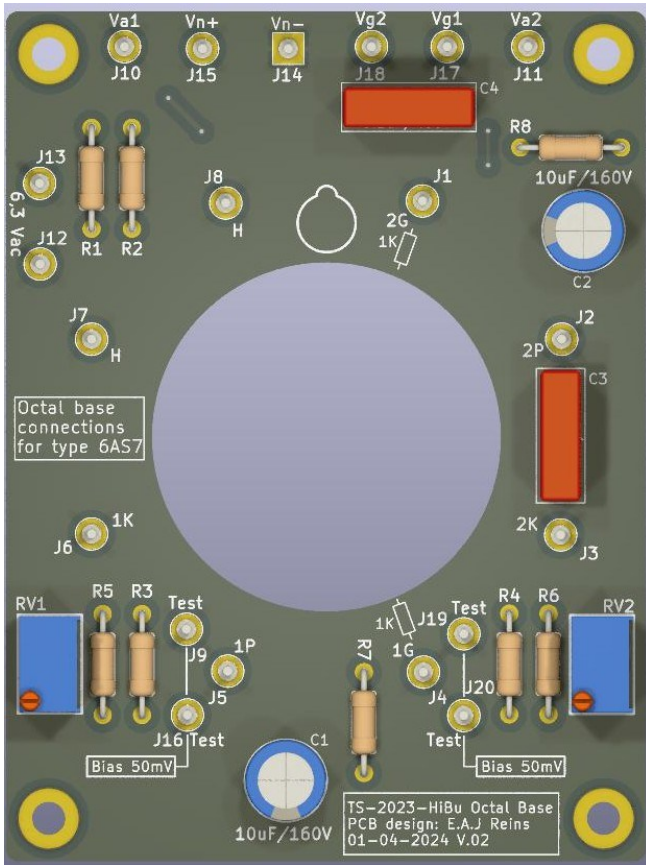

Connect the octal tube socket to the octal base PCB. **Ensure the orientation aligns with the keying notch.**

Connect the octal base PCB and the driver PCB to the power supply according to the wiring diagram.

**Do not insert the tubes yet.**

Turn on the amplifier and allow the amplifier to warm up.

Turn RV1 and RV2 on the octal base PCB fully counterclockwise. Measure the voltage between **J1 (grid2) → J3 (cathode2)** and **J4 (grid1) → J6 (cathode1)**. Both should read approximately 148 Vdc.

Turn off the amplifier and wait until all voltages have dissipated. **Now insert the tubes** and power the amplifier back on.

Gradually turn the potentiometers clockwise until you measure a voltage of 50 mV across resistors R3 and R4, using the test pins J9, J16, and J19, J20. This corresponds to a current of 50 mA flowing through each half of the 6AS7 tube.

Wait about 10 minutes, then readjust. Repeat this process again after 30 minutes, as new tubes require time to stabilize.

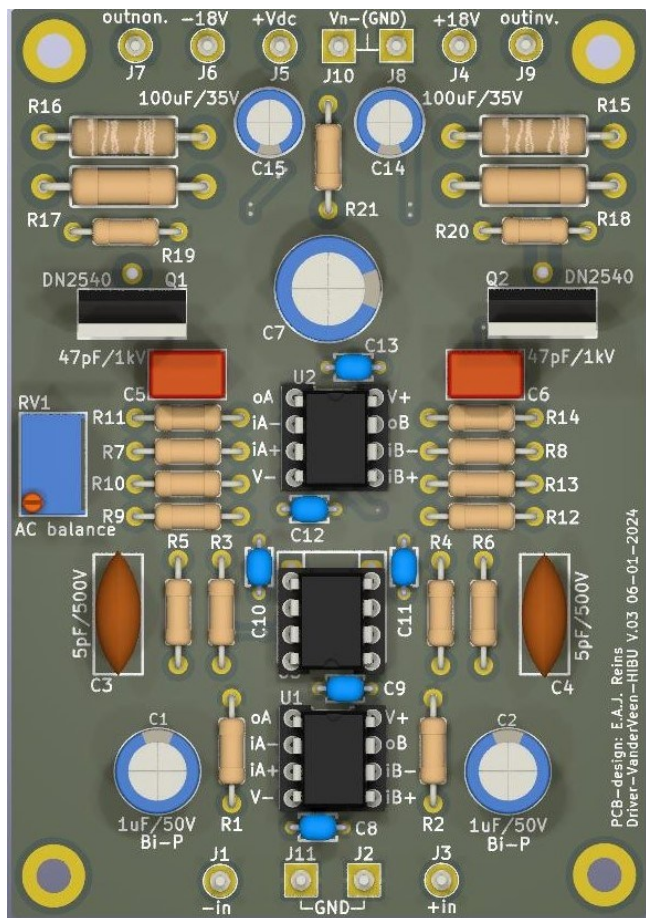

For adjusting the AC balance (RV1), it is ideal to use a spectrum analyzer, such as ARTA.

If you don't have a spectrum analyzer, follow these steps:

1. Generate a 1kHz tone using a tone generator.
2. Turn on the amplifier with a dummy load of 4 or 8 Ohms and increase the volume until you hear the output transformer humming.
3. Ensure the dummy load can handle the power.
4. Adjust RV1 (AC balance) until the sound from the transformer is minimized.
5. Check and, if necessary, adjust the bias to 50mV on the Octal base board.

Using a spectrum analyzer, you can fine-tune the AC balance for minimal second harmonic distortion using a 1kHz tone. Next, generate a 40Hz signal and adjust for the lowest distortion using RV1 or RV2 on the Octal base board. Repeat the procedure again for optimal settings.

Finally, recheck the + and -18V on the power supply, as the voltage may fluctuate slightly under load. Adjust if needed.







construction photos

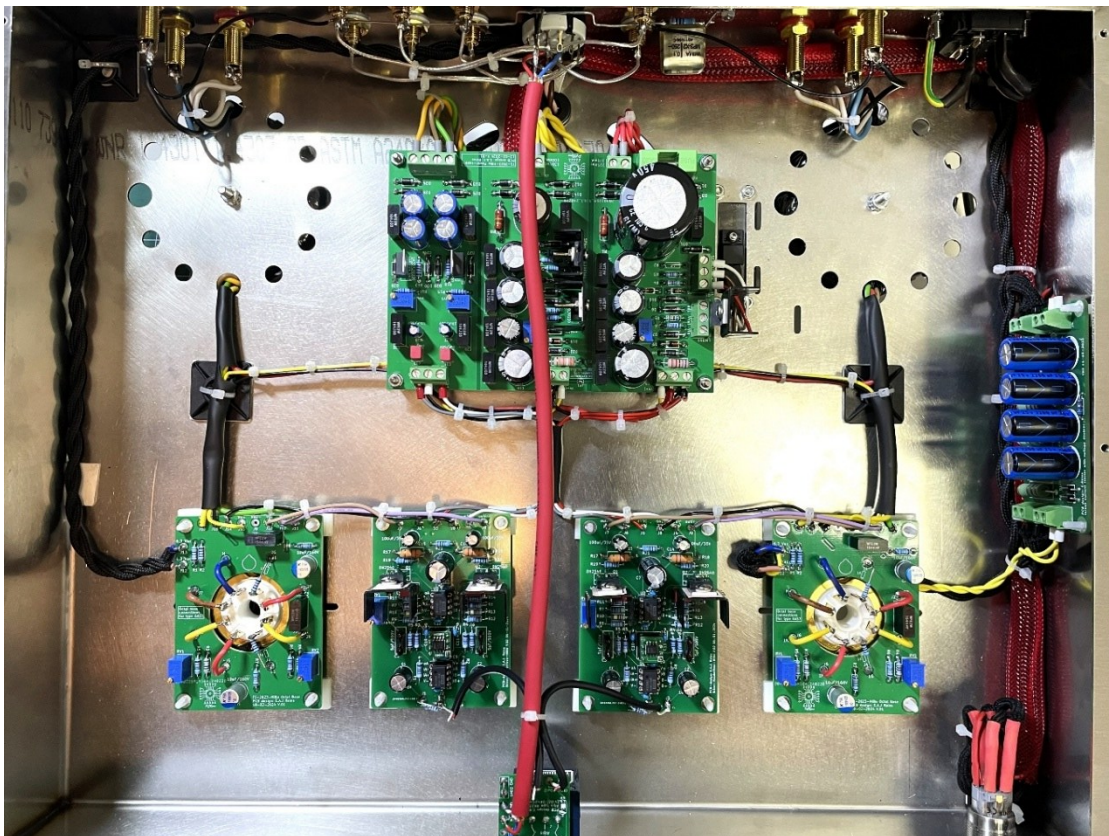
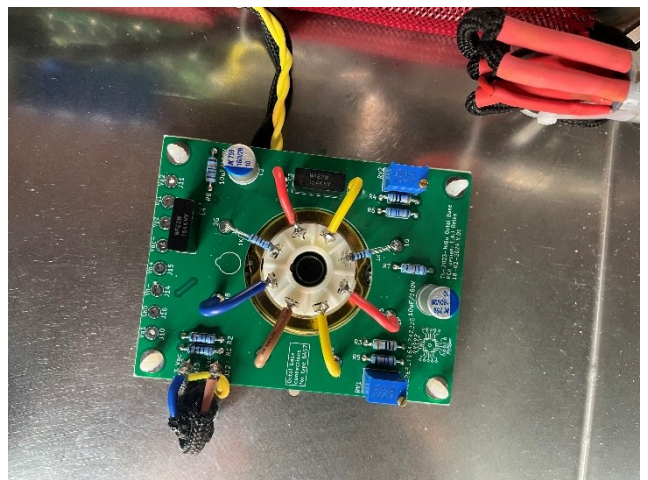
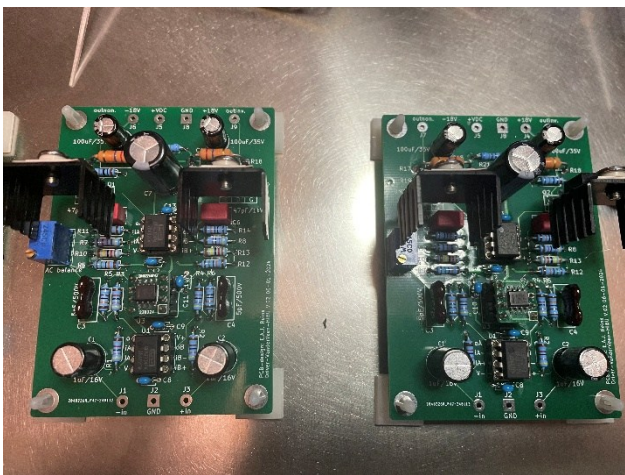
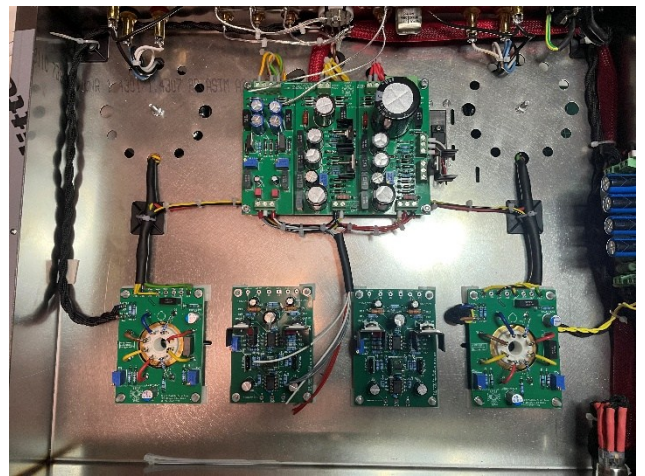
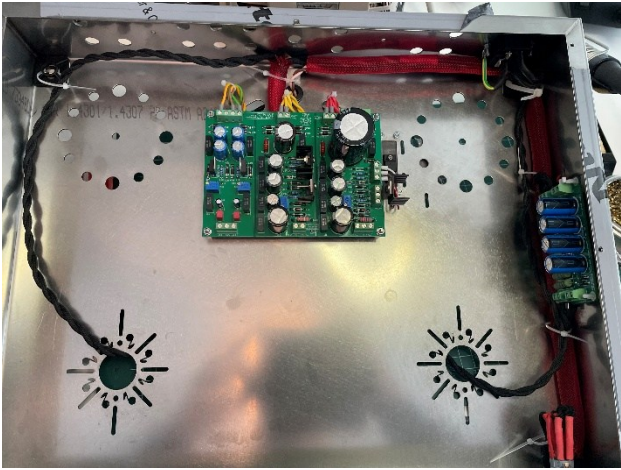



# Arta measurements

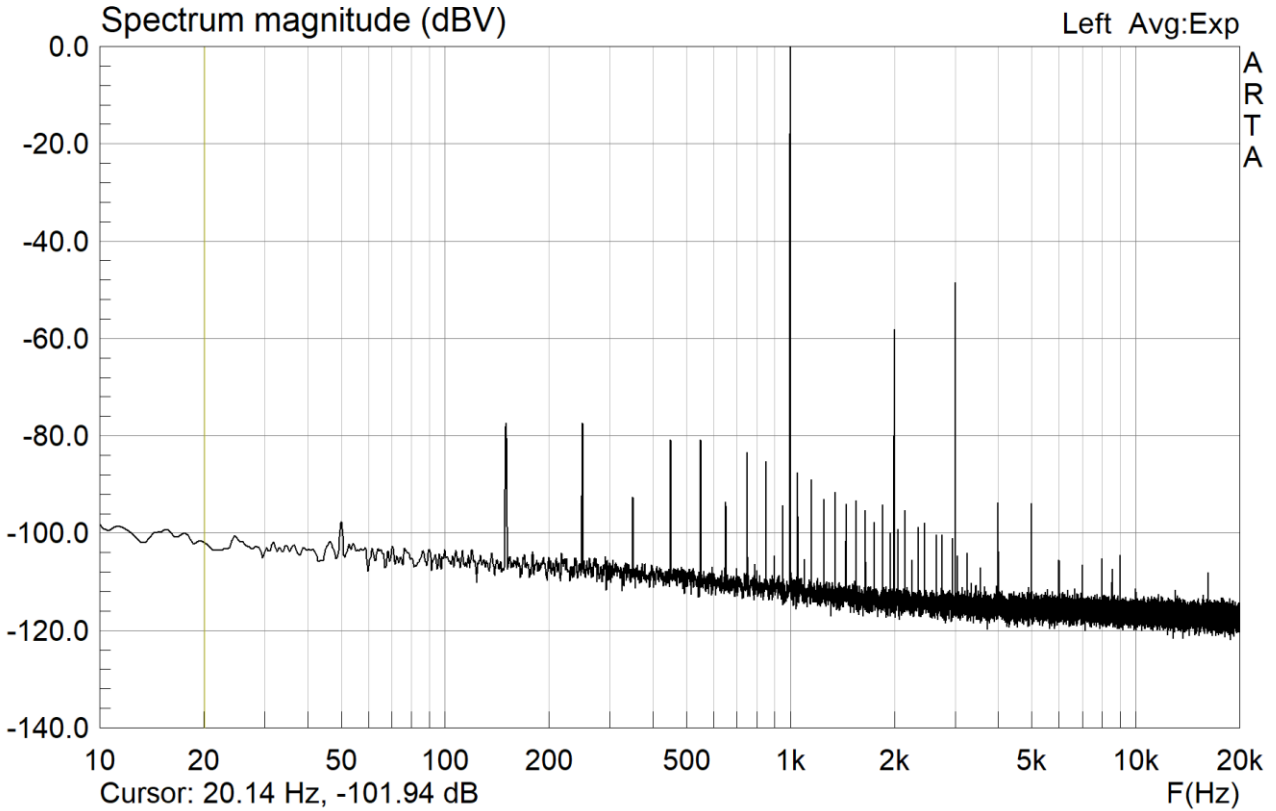

RMS = +9.0 dBV THD = 0.14% THD+N = 0.14%

Fs=48000Hz, FFTsize=131072, Window=Kaiser7

2024-06-16 11:33

PROJECT HiBu 2023-2024 1 Watt@8Ohm Left channel

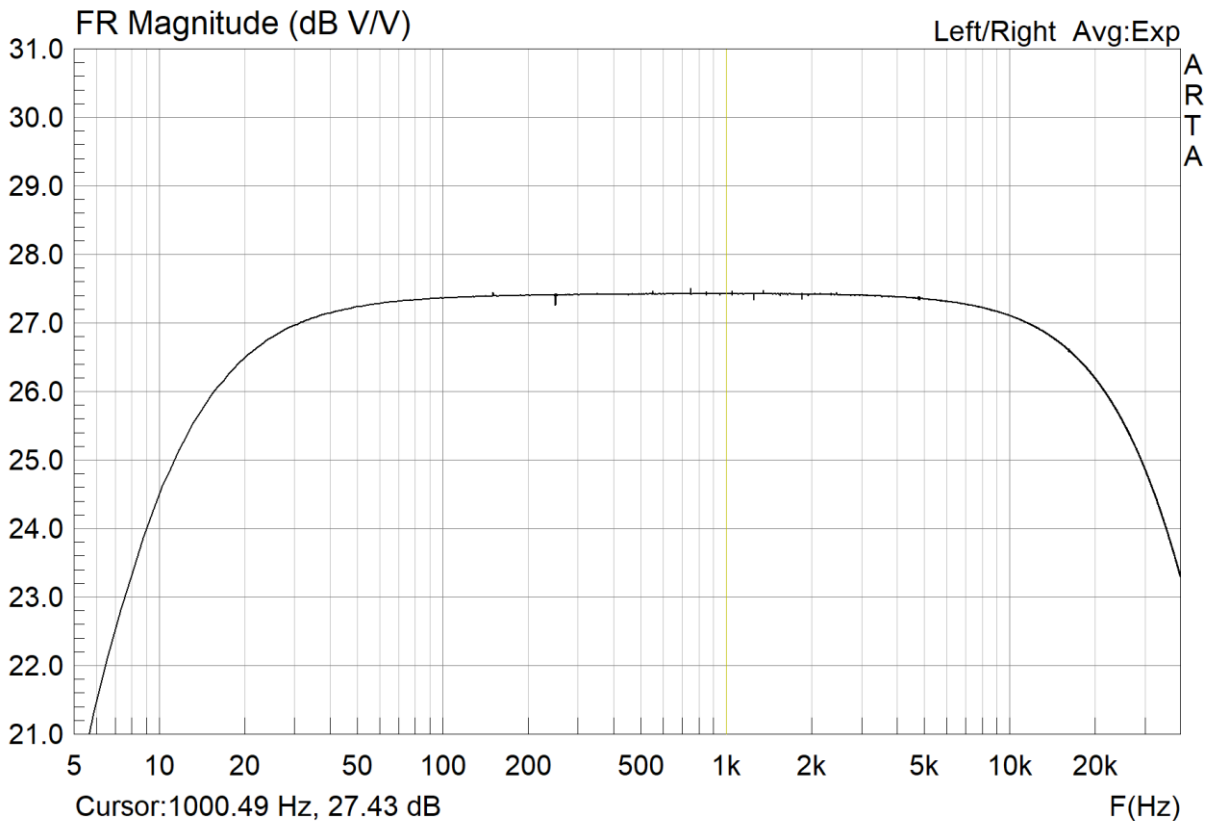

Dual Ch: Fs=96000Hz, FFTsize=131072, Window=Uniform

2024-06-16 11:39:33

PROJECT HiBu 2023-2024 1 Watt@8Ohm Left channel

